

## MAGNETISM AND ELECTROMAGNETISM

1.

In a step-down transformer, which of the following is greater in the secondary than in the primary?

- A. power
- B. current
- C. voltage
- D. number of turns

2.

Two identical bar magnets are placed as shown.

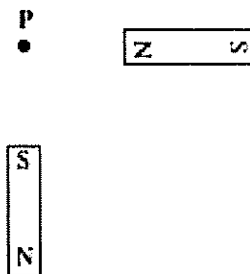

What is the direction of the magnetic field at P?

- A. 
- B. 
- C. 
- D. 

3.

A current of 4.3 A flows through a solenoid. The 620-turn solenoid is 14 cm long and has a 3.5 cm diameter.

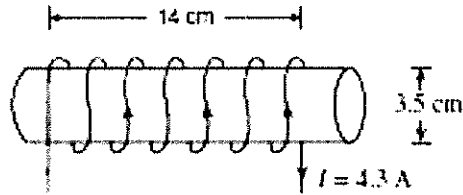

What are the direction and magnitude of the magnetic field inside the solenoid?

	DIRECTION OF FIELD	MAGNETIC FIELD STRENGTH (T)
A.	left	$2.4 \times 10^{-2}$
B.	left	$9.6 \times 10^{-2}$
C.	right	$2.4 \times 10^{-2}$
D.	right	$9.6 \times 10^{-2}$

4.

A conductor is moved to the right through four magnetic fields as shown below. In which case will the largest emf be generated?

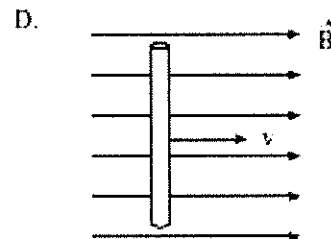
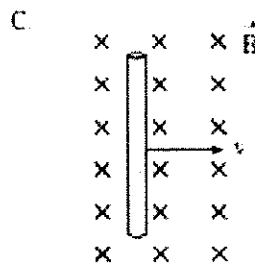
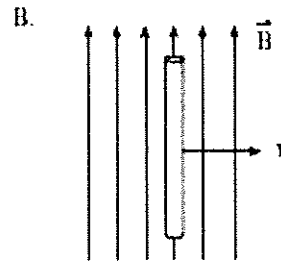
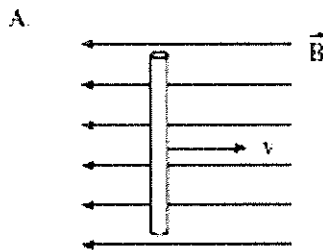

5.

A bar magnet is moved away from a coil as shown. What is the direction of the current through the resistor and the polarity of the left end of the coil?

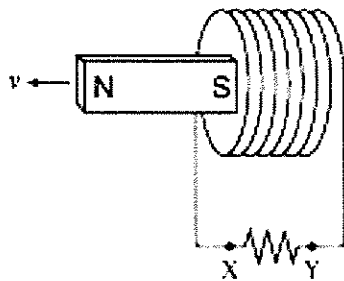

	DIRECTION OF CURRENT THROUGH THE RESISTOR	POLARITY OF LEFT END OF COIL.
A.	X to Y	North
B.	X to Y	South
C.	Y to X	North
D.	Y to X	South

6.

A 200-turn coil has a 15.2 V potential difference induced in it when the magnetic field changes from 0.42 T to 0.22 T in the opposite direction in  $3.2 \times 10^{-2}$  s. What is the radius of this coil?

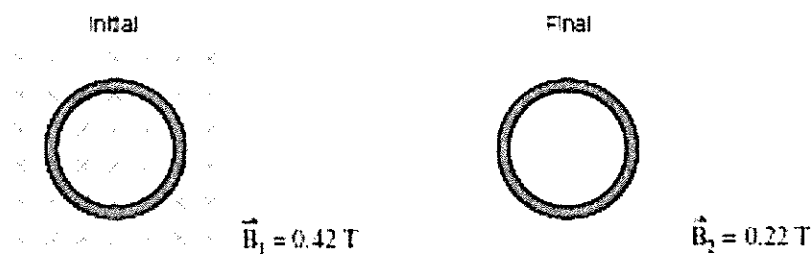

- A.  $3.5 \times 10^{-2}$  m
- B.  $5.1 \times 10^{-2}$  m
- C.  $5.9 \times 10^{-2}$  m
- D.  $6.2 \times 10^{-2}$  m

7.

A 0.20 m-long solenoid with 700 turns of conducting wire has a current of 1.5 A. What is the strength of the magnetic field inside the solenoid?

- A.  $2.4 \times 10^{-10}$  T
- B.  $5.4 \times 10^{-10}$  T
- C.  $2.9 \times 10^{-3}$  T
- D.  $6.6 \times 10^{-1}$  T

8.

A conducting wire is carrying a current towards the top of the page as shown below.



Due to the presence of a magnetic field the wire is experiencing a magnetic force directed out of the page. What is the direction of the magnetic field?

- A. left
- B. right
- C. into the page
- D. out of the page

9.

A proton is travelling in a circular path of radius 0.19 m perpendicular to a 0.55 T magnetic field. What is the momentum of this proton?

- A.  $2.8 \times 10^{-47} \text{ kg} \cdot \text{m/s}$
- B.  $5.8 \times 10^{-28} \text{ kg} \cdot \text{m/s}$
- C.  $1.7 \times 10^{-20} \text{ kg} \cdot \text{m/s}$
- D.  $1.0 \times 10^7 \text{ kg} \cdot \text{m/s}$

10.

The single rectangular loop of wire shown below is being pulled out of the 0.50 T magnetic field at a constant speed. An emf of 0.60 V is being generated in the loop and the length of side 'ℓ' is 0.30 m.

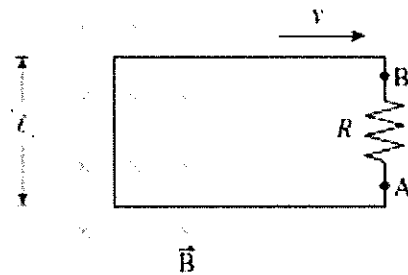

What is the speed of the loop and what is the direction of the current through the resistor?

	SPEED OF LOOP (m/s)	DIRECTION OF CURRENT
A.	4.0	B to A
B.	0.090	A to B
C.	4.0	A to B
D.	0.090	B to A

11.

A changing magnetic field induces a current in the loop of wire shown below.

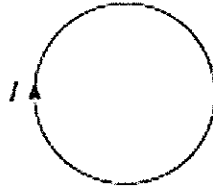

Which of the following correctly describes the magnetic field?

- A. directed into the page and decreasing
- B. directed out of the page and decreasing
- C. directed towards the top of the page and decreasing
- D. directed towards the bottom of the page and decreasing

12.

The current through an electric motor is increasing. The applied voltage is constant. Which of the following is correct?

- A. The motor's back emf is constant.
- B. The motor's back emf is increasing.
- C. The motor's back emf is decreasing.
- D. The motor's back emf is increasing then decreasing.

13.

(5 marks)

Two solenoids, placed side by side as shown, are functioning together as an ideal transformer. The first solenoid has 230 coils and the second has 46 coils. An ac power supply provides the first solenoid with a current of 0.35 A.

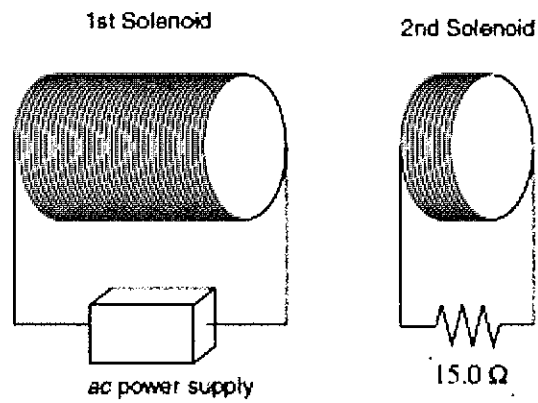

What power is dissipated in the  $15.0\ \Omega$  resistor connected to the second coil?

14.

(5 marks)

A block of metal moves north at 180 m/s, perpendicular to a magnetic field.

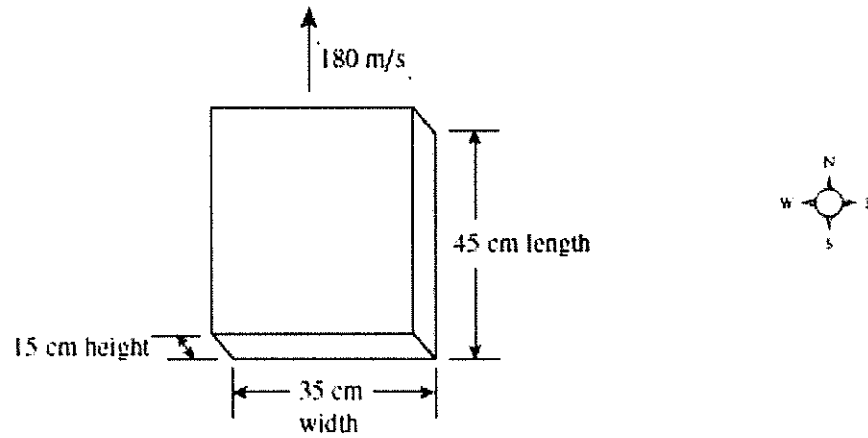

If an electron in the block experiences a force of  $7.2 \times 10^{-18}$  N vertically upwards out of the page, what are the magnetic field strength and direction?

What is the potential difference developed across this block?



15.

A coil of area  $0.70 \text{ m}^2$  is in a  $0.20 \text{ T}$  magnetic field which is perpendicular to the face of the coil. What is the magnetic flux through the coil?

- A.  $0.10 \text{ Wb}$
- B.  $0.14 \text{ Wb}$
- C.  $0.29 \text{ Wb}$
- D.  $3.5 \text{ Wb}$

16.

A proton travelling at a certain speed follows a circular path of radius  $0.24 \text{ m}$  while in a magnetic field. An alpha particle with twice the charge and four times the mass of the proton is travelling at the same speed inside the same magnetic field. (Both particles are travelling perpendicular to the field.) What is the radius of the alpha particle's path?

- A.  $0.12 \text{ m}$
- B.  $0.24 \text{ m}$
- C.  $0.48 \text{ m}$
- D.  $0.96 \text{ m}$

17.

A conducting rod is placed on a U-shaped metal conductor containing a  $9.0\ \Omega$  resistor. The rod is moved to the right at a constant speed of  $6.2\ \text{m/s}$  through a  $0.33\ \text{T}$  magnetic field as shown.

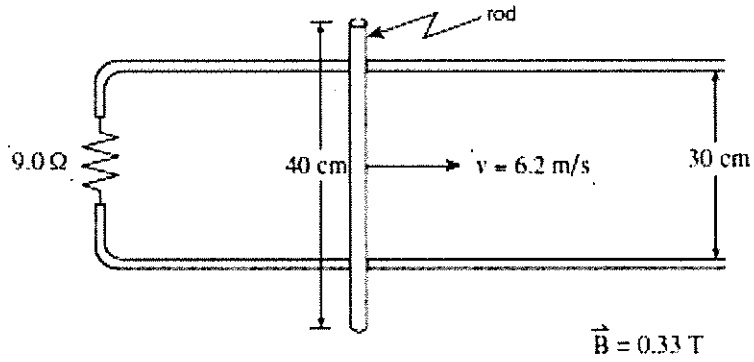

What are the magnitude and direction of the current induced in the rod?

	MAGNITUDE OF CURRENT	DIRECTION OF CURRENT
A.	68 mA	towards top of page
B.	68 mA	towards bottom of page
C.	91 mA	towards top of page
D.	91 mA	towards bottom of page

18.

Due to the presence of a changing magnetic field a current is flowing in the single circular loop of conducting wire as shown below.

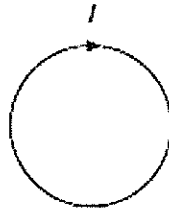

Which of the following correctly describes the magnetic field?

- A. directed to the left and increasing
- B. directed to the right and increasing
- C. directed into the page and increasing
- D. directed out of the page and increasing

19.

The back emf being produced by an electric motor is increasing. The applied voltage is constant. Which of the following is correct?

- A. The current through the motor is constant.
- B. The current through the motor is increasing.
- C. The current through the motor is decreasing.
- D. The current through the motor is increasing then decreasing.

