

ELECTRIC CIRCUITS 4

1.

A 6.0 V battery is connected through a switch to a 3.0 Ω resistor as shown below.

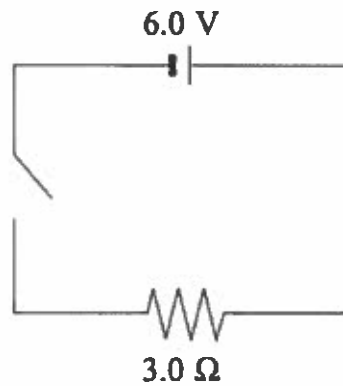

What total charge flows through the resistor if the switch is closed for 40 s ?

- A. 2.0×10^{-9} C
- B. 2.0 C
- C. 80 C
- D. 480 C

2.

Which of the following diagrams shows meters correctly placed to measure the circuit current and the terminal voltage of the battery?

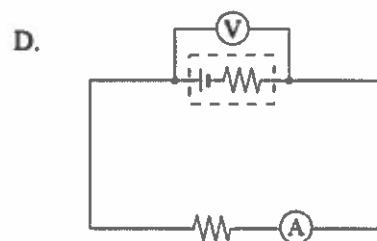
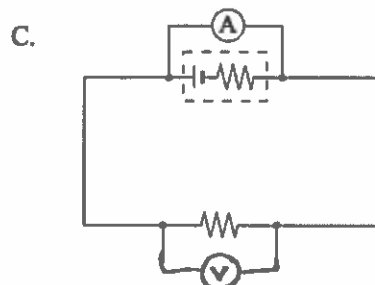
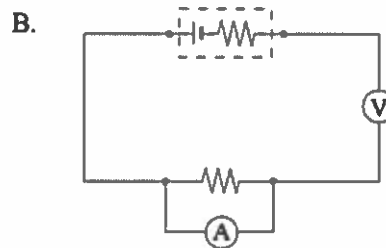
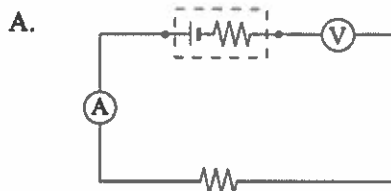

3.

What is the terminal voltage of the cell in the circuit shown in the diagram below?

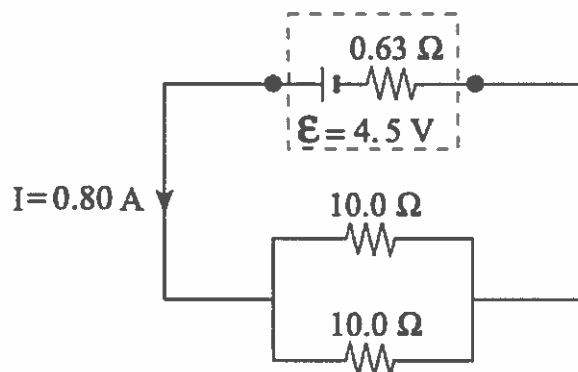

- A. 0.50 V
- B. 3.5 V
- C. 4.0 V
- D. 4.5 V

4.

What is the power dissipated in resistor R_1 in the circuit shown in the diagram below?

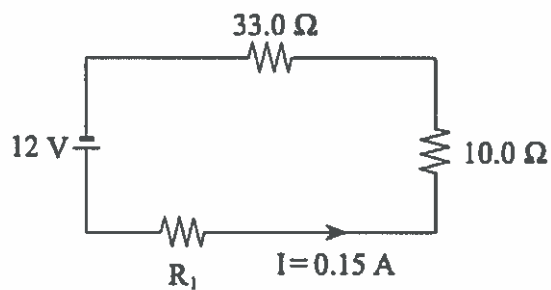

- A. 0.83 W
- B. 0.97 W
- C. 1.8 W
- D. 2.8 W

5.

The diagram below shows part of an electrical circuit.

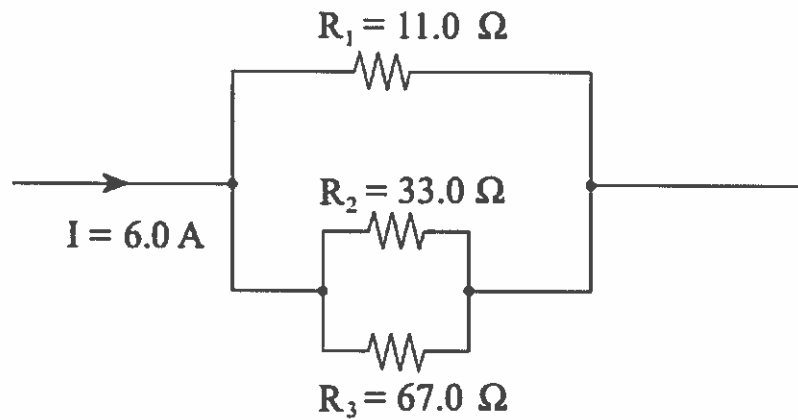

What is the current through resistor R_1 ?

- A. 2.0 A
- B. 3.0 A
- C. 4.0 A
- D. 6.0 A

6.

What is the voltage, V , of the power supply shown in the circuit?

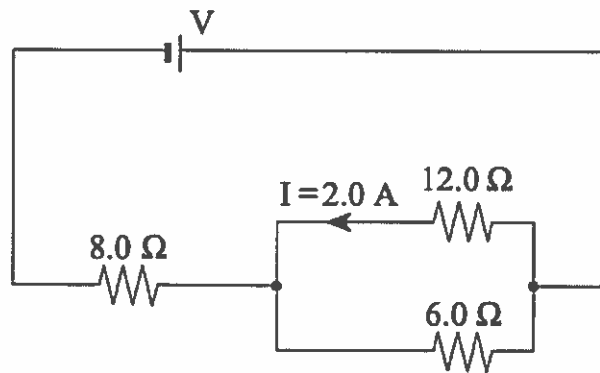

- A. 24 V
- B. 52 V
- C. 72 V
- D. 96 V

7.

What is the emf of the battery shown?

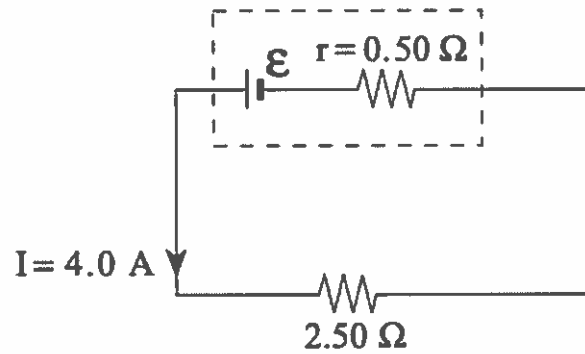

- A. 2.0 V
- B. 8.0 V
- C. 10 V
- D. 12 V

8.

Two identical resistors connected in series have a total power output of 400 W. Assuming V and R remain constant, what would the total power output be when the resistors are re-connected in parallel?

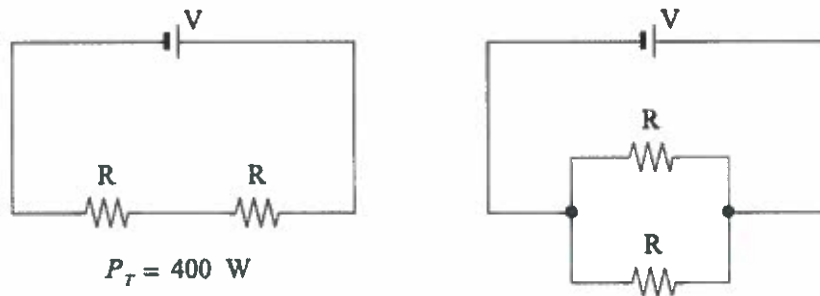

- A. 200 W
- B. 400 W
- C. 800 W
- D. 1 600 W

9.

Which of the following correctly shows the direction of conventional current and electron flow?

A.

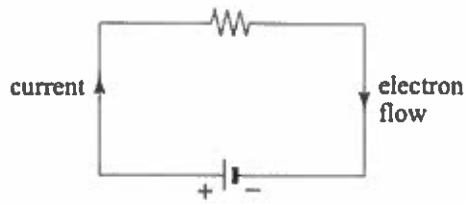

B.

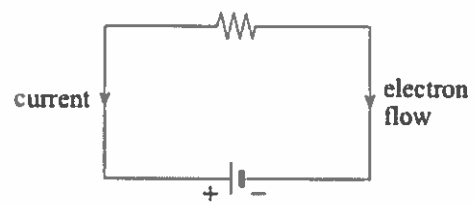

C.

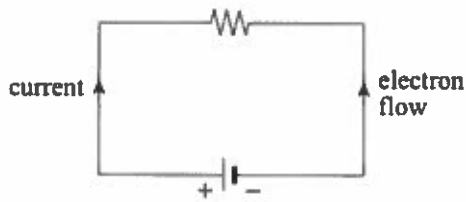

D.

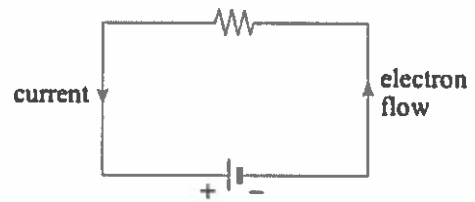

10.

What current flows through the 11.0Ω resistor?

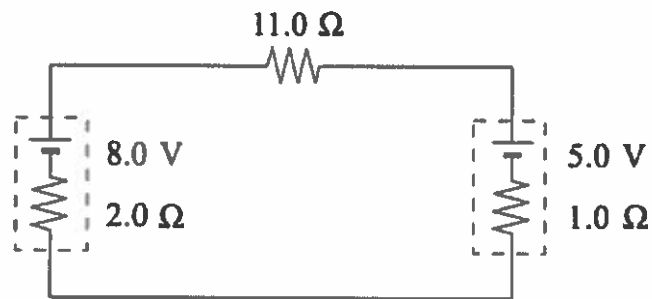

- A. 0.21 A
- B. 0.27 A
- C. 0.93 A
- D. 1.2 A

11.

Calculate the current through the 6.0Ω resistor in the circuit shown.

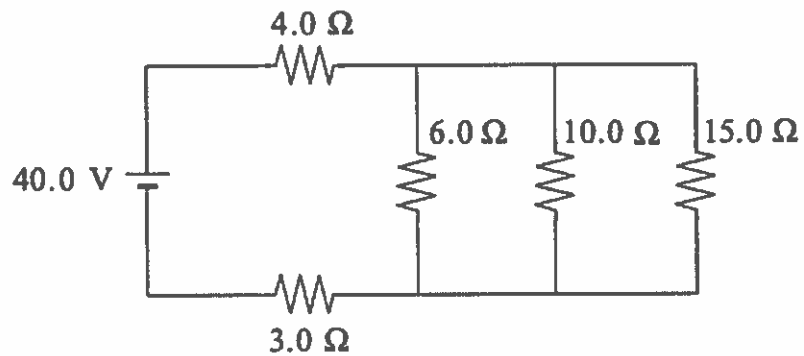

- A. 1.1 A
- B. 2.0 A
- C. 4.0 A
- D. 6.7 A

12.

In the following circuit, determine the value of resistor R.

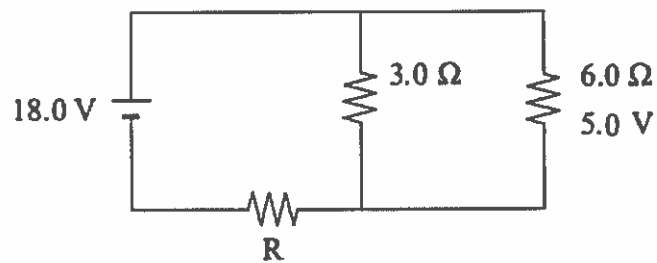

- A. 3.2Ω
- B. 5.2Ω
- C. 9.0Ω
- D. 23Ω

13.

A battery provides 3.20 W of power to an external resistance. What power is dissipated as heat by the internal resistance within the battery?

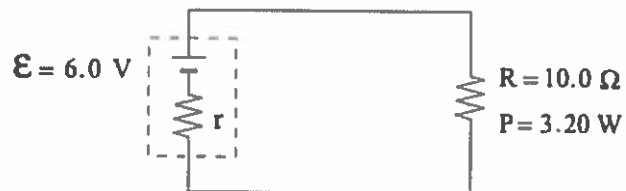

- A. 0.19 W
- B. 3.4 W
- C. 3.6 W
- D. 60 W

14.

A 75 W bulb is connected across a 120 V source. While the bulb is lighted, what is the effective resistance of the bulb?

- A. 0.62 Ω
- B. 1.6 Ω
- C. 47 Ω
- D. 190 Ω

