

ELECTRIC CIRCUITS 3

1.

Which of the following statements provides valid reasoning for the transmission of electric energy at high potential?

(100-800 kV)
(~10% loss)

- A. At high potential there will be low current resulting in low power loss.
- B. At high potential there will be high current resulting in high power loss.
- C. At high potential there will be low line resistance resulting in low power loss.
- D. At high potential there will be high line resistance resulting in high power loss.

The higher the voltage, the lower the current. The lower the current, the lower the resistance, => lower losses of P

What is the terminal voltage of the battery in the circuit shown in the diagram?

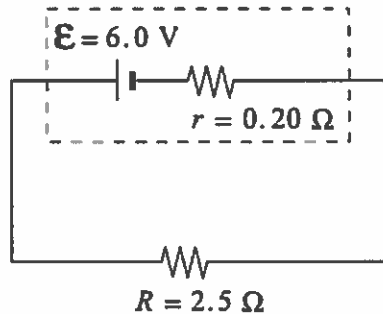

• Find I

$$I = \frac{\mathcal{E}}{R_{\text{eq}}}$$

$$= \frac{6.0}{(2.5 + 0.20)}$$

$$= 2.2 \text{ A}$$

- A. 0.44 V
- B. 5.6 V
- C. 6.0 V
- D. 6.4 V

$$V_{\text{term}} = \mathcal{E} - Ir$$

$$= 6.0 - (2.2)(0.2)$$

$$= \underline{5.6 \text{ V}}$$

3.

What is the power dissipated in the unknown resistor R_x in the circuit below?

$$P = IV = I^2 R$$

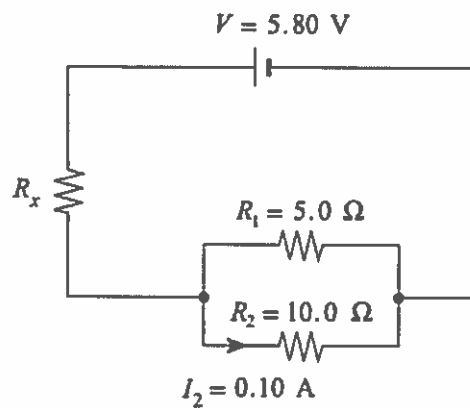

$$\begin{aligned} V_2 &= R_2 I_2 \\ &= (10.0)(0.10) \\ &= 1.0 \text{ V} \end{aligned}$$

$$\begin{aligned} V_2 &= V_1 \text{ (Parallel resistors)} \\ &= V_{\text{loop}} \end{aligned}$$

$$\begin{aligned} V_R &= V_{\text{Battery}} - V_{\text{loop}} \\ &= 5.80 - 1.0 \\ &= \underline{4.80 \text{ V}} \end{aligned}$$

- A. 0.30 W
- B. 1.4 W**
- C. 1.7 W
- D. 2.0 W

$$\begin{aligned} I_R &= I_{\text{TOT}} = I_1 + I_2 \\ &= 0.20 + 0.10 \\ &= \underline{0.30 \text{ A}} \end{aligned}$$

$$\begin{aligned} P_R &= I_R V_R = (0.30)(4.8) \\ &= \underline{1.44 \text{ W}} \end{aligned}$$

$$I_1 = \frac{V_1}{R_1} = \frac{1.0}{5.0} = 0.20 \text{ A}$$

4.

In which of the following circuits is the voltmeter placed correctly to measure the terminal voltage of the battery, and the ammeter placed correctly to measure the current through the light bulb (⊕)?

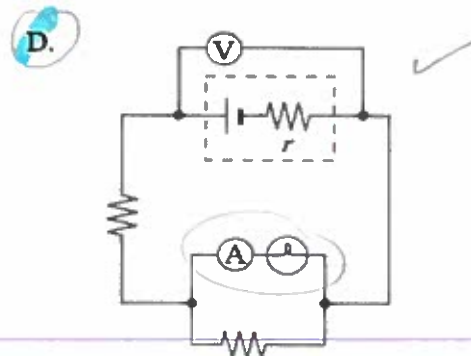
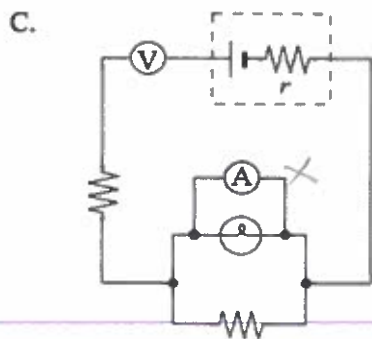
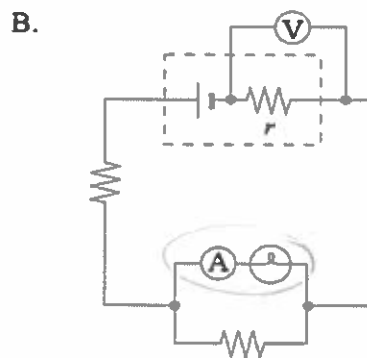
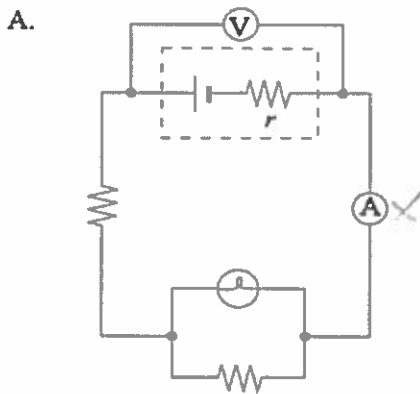

5.

What is the current leaving the battery in the circuit below?

$$P = IV = I^2 R$$

$$I = \frac{P}{V}$$

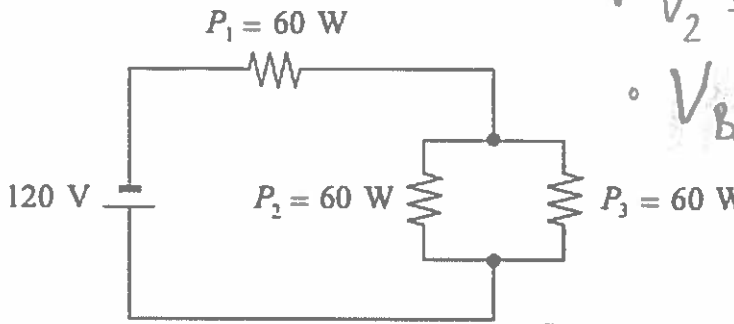

• $V_2 = V_3 = V_{loop}$

• $V_{battery} = V_1 + V_{loop}$

$120 = V_1 + V_2$

A. 1.3 A $120 = V_1 + 2V_1$

B. 1.5 A $120 = \frac{60}{3} + \frac{60}{3}$

C. 2.0 A

D. 4.0 A $V_1 = 40V$

6. $I_1 = \frac{P_2}{V_1} = \frac{60}{40} = 1.5A$

$I_2 + I_3 = I_1 = I_{total}$

$\frac{60}{V_2} + \frac{60}{V_3} = \frac{60}{V_1}$

$2 \cdot \frac{60}{V_2} = \frac{60}{V_1}$

$\frac{120}{V_2} = \frac{60}{V_1}$

$120V_1 = 60V_2$

$2V_1 = V_2$

Which of the following correctly labels arrows 1 and 2 and polarities X and Y in the circuit below?

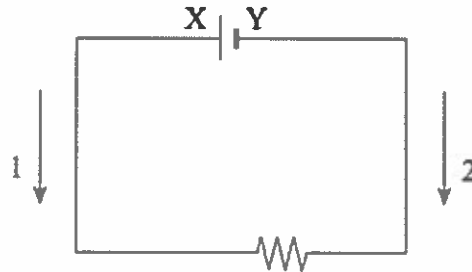

	ARROW 1	ARROW 2	POLARITY X	POLARITY Y
A.	Electron Flow	Conventional Current	Positive ✓	Negative ✓
B.	Electron Flow	Conventional Current	Negative	Positive
C.	Conventional Current ✓	Electron Flow ✓	Positive ✓	Negative ✓
D.	Conventional Current ✓	Electron Flow ✓	Negative	Positive

7.

Switch S is originally open as shown in the circuit below.

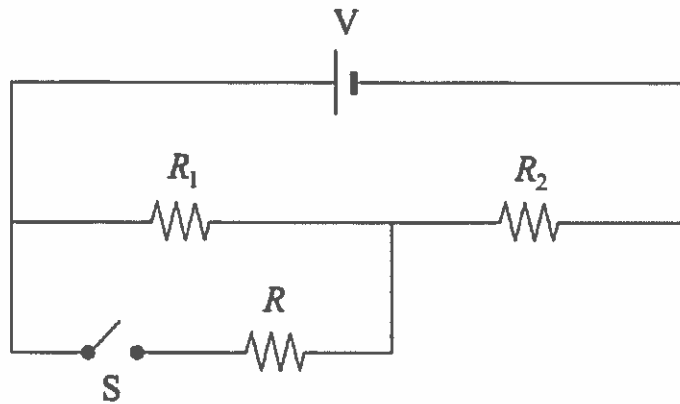

How does the current through resistors R_1 and R_2 change when switch S is closed?

$= R_{eq} \downarrow$

as R in parallel is added

V_B is constant

$$I = \frac{V_B}{R_{eq}} \Rightarrow I_{tot} \uparrow$$

	CURRENT THROUGH R_1	CURRENT THROUGH R_2
A.	increases	increases
B.	increases	decreases
C.	decreases ✓	increases ✓
D.	decreases ✓	decreases

8.

What is the power output of the 6.0Ω resistor in the diagram?

$$P = IV = I^2 R$$

$$I = \frac{V_B}{R_{eq}} = \frac{30}{(4+6)} = 3A$$

$$\Rightarrow P = 6 \times 3^2 = 54W$$

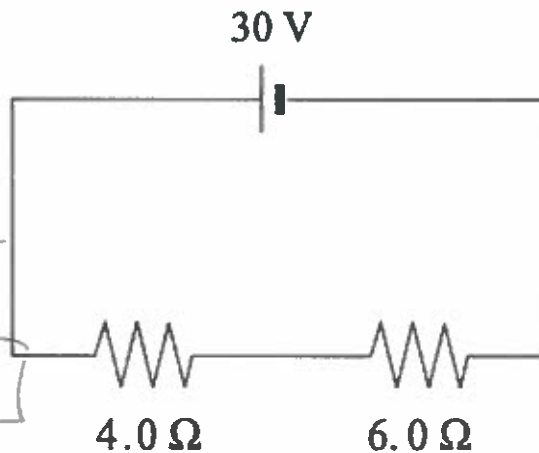

- A. 36 W
- B. 54 W
- C. 90 W
- D. 150 W

9.

A 12 V power supply is connected to an 8.0 Ω resistor for 50 s. How much charge passes through the resistor?

- A. 1.9 C
- B. 75 C**
- C. 900 C
- D. 4 800 C

$$I = q/t \rightarrow q = I \cdot \Delta t$$

$$I = \frac{V}{R} = \frac{12}{8.0} = 1.5 A$$

$$\Rightarrow q = (1.5)(50) = \boxed{75 C}$$

10.

The circuit shown below includes two ammeters and two voltmeters. Identify the correct placement of these meters.

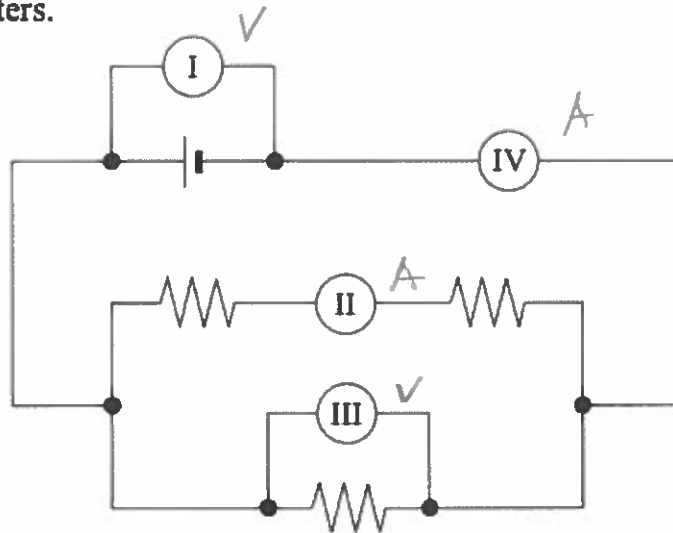

	AMMETERS	VOLTMETERS
A.	I, II	III, IV
B.	I, III	II, IV
C.	II, IV ✓	I, III ✓
D.	III, IV	I, II

11.

A 120 V supply is connected to a heater of resistance 15 Ω. What must the resistance of another heater be in order to produce the same power output when connected to a 240 V supply?

A. 3.8 Ω

B. 7.5 Ω

C. 30 Ω

D. 60 Ω

• $P = IV = I^2 R \rightarrow$

• $I = \frac{P}{V}$ and $\sqrt{\frac{P}{R}}$

$P_1 = I_1 V_1$

$P_2 = I_2 V_2$

$I_1^2 R_1 = I_2^2 R_2$

$P_1 = P_2 \Rightarrow I_1 (120) = I_2 (240)$

$(2I_2)^2 (15) = I_2^2 R_2$

$I_1 = 2I_2$

$\frac{4I_2^2 \cdot 15}{I_2^2} = R_2$

$R_2 = 60 \Omega$

12.

What is the voltage of the power supply shown in the diagram?

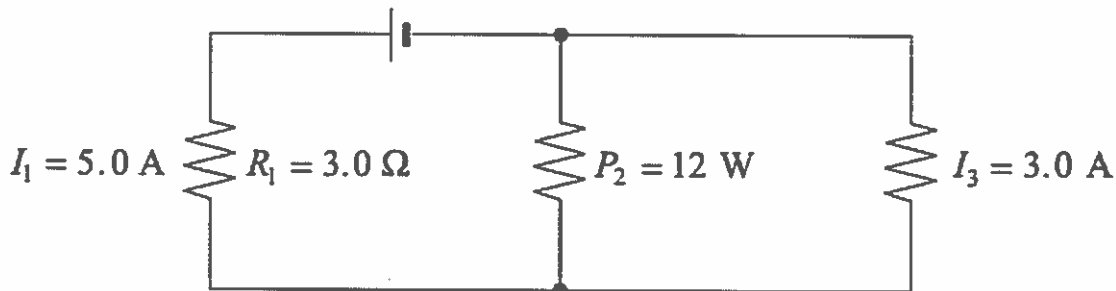

A. 12 V

B. 19 V

C. 21 V

D. 27 V

• $V_1 = (5.0)(3.0) = 15 \text{ V}$

• $V_3 = V_2 = V_{\text{loop}}$

• $I_2 = I_1 - I_3 = 2.0 \text{ A}$

$V_{\text{Battery}} = V_1 + V_{\text{loop}} = 15 + 6$

• $P_2 = I_2 V_2$
 $V_2 = \frac{P_2}{I_2} = \frac{12}{2.0} = 6 \text{ V}$

$= 21 \text{ V}$