

# CIRCUIT ELECTRICITY

1.

Consider the circuit element shown below.



The voltage across the resistor increases from  $V$  to  $2V$ . The resistance remains the same. By what factor has the current changed?

- A.  $\frac{1}{4}$
- B.  $\frac{1}{2}$
- C. 2
- D. 4

2.

A 12.0 V power supply is connected to 4 resistors as shown.

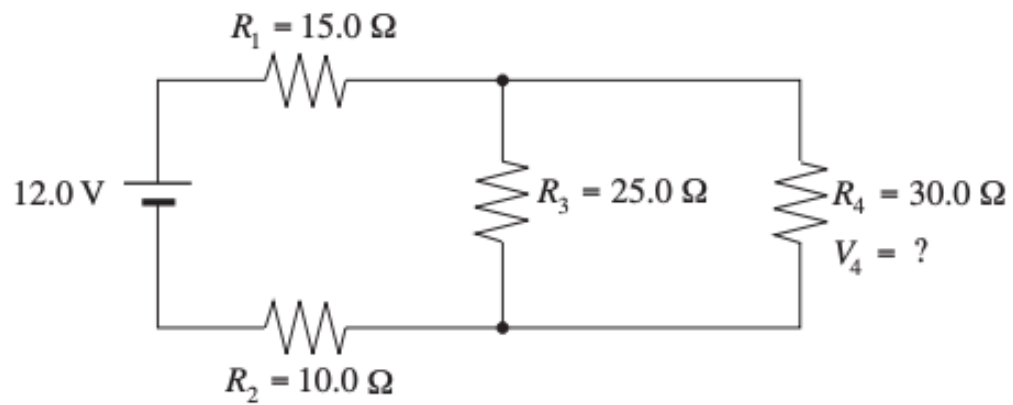

What is the potential difference,  $V_4$ , across the  $30.0 \Omega$  resistor?

- A. 2.12 V
- B. 4.24 V
- C. 9.32 V
- D. 12.0 V

3.

An electric motor is being supplied with 500 W of power at 120 V. The resistance of the motor is  $8.0 \Omega$ . What current is being supplied to the motor?

- A. 4.2 A
- B. 7.9 A
- C. 15 A
- D. 63 A

4.

A circuit junction is shown below.

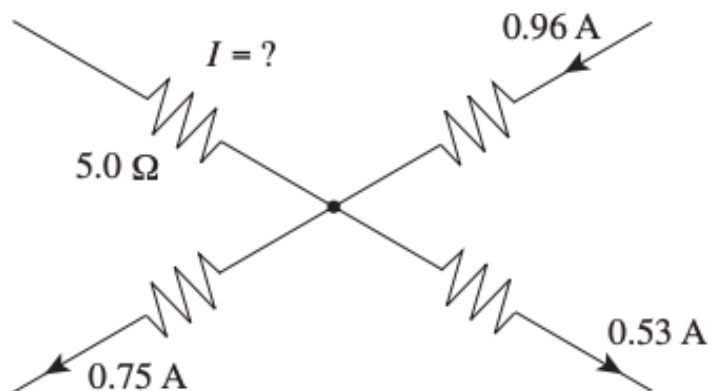

What is the current and its direction through the  $5.0 \Omega$  resistor?

	CURRENT	DIRECTION
A.	0.32 A	away from junction
B.	0.32 A	towards the junction
C.	2.24 A	away from junction
D.	2.24 A	towards the junction

5.

A power source is providing a constant voltage,  $V$ , to the circuit shown below.

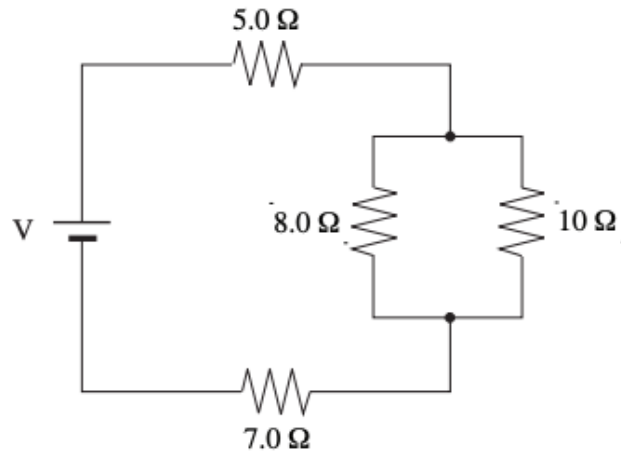

If the  $8.0\ \Omega$  resistor is removed from the circuit what happens to the equivalent resistance of the circuit and the current through the  $7.0\ \Omega$  resistor?

	EQUIVALENT RESISTANCE OF THE CIRCUIT	CURRENT THROUGH $7.0\ \Omega$ RESISTOR
A.	Increases	Decreases
B.	Decreases	Increases
C.	Increases	Increases
D.	Decreases	Decreases

6.

In an electric circuit,  $6.25 \times 10^{18}$  electrons flow past one point in  $0.10\ \text{s}$ . What is the current?

- A.  $1.6 \times 10^{-19}\ \text{A}$
- B.  $1.0\ \text{A}$
- C.  $10\ \text{A}$
- D.  $6.25 \times 10^{19}\ \text{A}$

7.

Three identical light bulbs are placed in a circuit as shown.

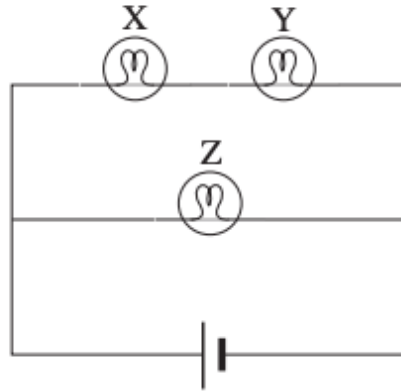

Which of the following is correct?

- A. The voltage and current are the same for all three bulbs.
- B. The current in light bulb Z is less than the current in light bulb X.
- C. The current in light bulb Z is greater than the current in light bulb Y.
- D. The voltage across light bulb Z is less than the voltage across light bulb X.

8.

What current would be drawn from the power supply in the circuit shown below?

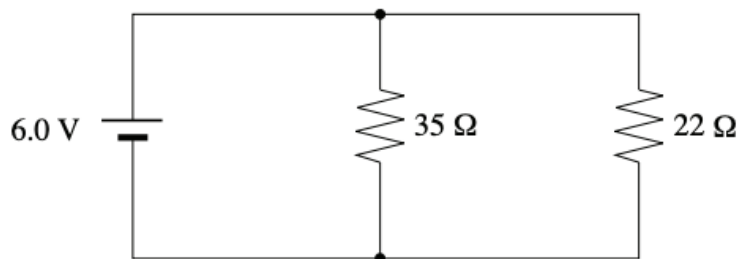

- A. 0.11 A
- B. 0.17 A
- C. 0.27 A
- D. 0.44 A

9.

A student needs to connect a voltmeter to measure the potential difference across the parallel resistors in the circuit shown below.

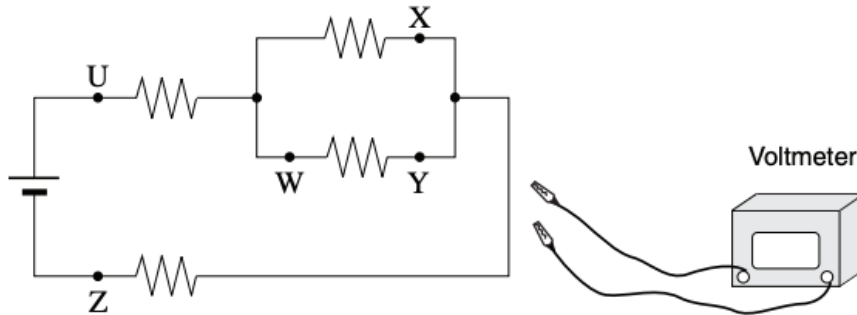

Across which two connection points should the student connect the voltmeter?

- A. U and Z
- B. X and Y
- C. X and W
- D. W and Z

10.

What is the current  $I$  through the  $10.0\ \Omega$  resistor in the circuit shown below?



- A. 0.27 A
- B. 0.30 A
- C. 0.34 A
- D. 2.3 A

11.

What power is dissipated by the  $15\ \Omega$  resistor in the circuit shown?

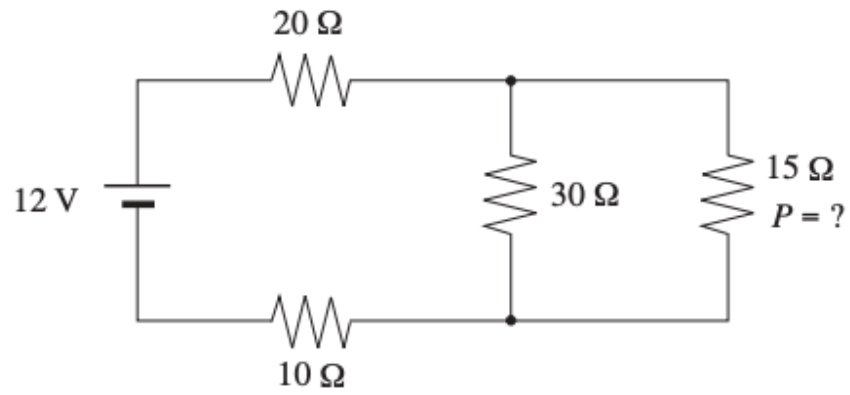

- A. 0.60 W
- B. 1.4 W
- C. 6.7 W
- D. 15 W

12.

What is the terminal voltage of the battery in the circuit shown?

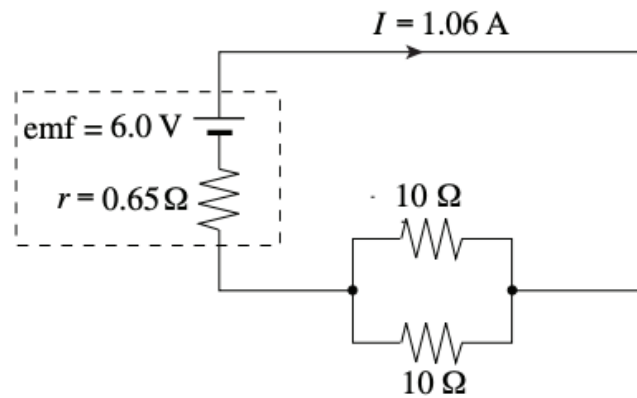

- A. 0.69 V
- B. 5.3 V
- C. 6.0 V
- D. 6.7 V